



ELECTRIC TILLER

RAC1200ET

USER GUIDE

CAUTION: Read this manual before using this machine!

CONTENTS

1. INTENDED USE	3
2. SAFETY INSTRUCTIONS	3
3. YOUR PRODUCT	11
4. ASSEMBLY	13
5. OPERATION	16
6. MAINTENANCE AND STORAGE	17
7. TROUBLESHOOTING	18
8. DISPOSAL	18
9. DECLARATION OF CONFORMITY	19
10. WARRANTY	20
11. PRODUCT FAILURE	21
12. WARRANTY EXCLUSIONS	22

1. INTENDED USE

This device is only intended as an electric tiller for aerating lawns and grassy areas in private domestic and hobby gardens.

It is not designed for use in public areas, parks, sports areas, and in agriculture and forestry.

Using the application for any other purpose is considered incorrect and unapproved.

The manufacturer is not liable for any damage or injury resulting from such use. The user is entirely responsible for any associated risks.

2. SAFETY WARNINGS

Read the operating instructions and act accordingly. Keep it for general use.

Comply with the safety information and the warning on the device.

Always use this device according to the instructions in this manual.

1) TRAINING

- a) Read the instructions carefully. Be familiar with the controls and the proper use of the equipment.
- b) Never allow children or people unfamiliar with these instructions to use the machine. Local regulations can restrict the age of the operator.
- c) Never work while people, especially children, or pets are nearby.
- d) Keep in mind that the operator or user is responsible for accidents or hazards occurring to other people or their property.

2) PREPARATION

- a) While working, always wear substantial footwear and long trousers. Do not operate the equipment when barefoot or wearing open sandals.

- b) Thoroughly inspect the area where the equipment is to be used and remove all objects which can be thrown up by the machine.
- c) Before using, always visually inspect to see that the tools are not worn out or damaged. Replace worn out or damaged elements and bolts in sets to preserve balance.

3) OPERATION

- a) Do not operate the engine in a confined space where dangerous carbon monoxide fumes can collect.
- b) Work only in daylight or in good artificial light.
- c) Always be sure of your footing on slopes.
- d) Walk, never run with the machine.
- e) Work across the slopes, never up and down.
- f) Exercise extreme caution when changing direction on slopes.
- g) Do not work on excessively steep slopes.
- h) Use extreme caution when reversing or pulling the machine towards you.
- i) Do not change the engine governor settings or over speed the engine.
- j) Start the engine carefully according to manufacturer instructions and with feet well away from the tool.
- k) Do not put your hands or feet near or under rotating parts.
- l) Never pick up or carry a machine while the engine is running.
- m) Stop the engine when you leave the machine.

4) MAINTENANCE AND STOCKAGE

- a) Keep all nuts, bolts and screws tight to ensure the equipment is in safe working condition.
- b) Allow the engine to cool before storing in any enclosure.
- c) To reduce the fire hazard, keep the engine free of vegetative material and excessive grease.
- d) Replace worn or damaged parts for safety.

5) BEFORE OPERATION

- a) The machine should always be used according to the manufacturer's instructions in the instruction manual.
- b) The machine must be stopped when carrying out maintenance and cleaning operations, when changing tools or when transported by means other than under its own power.
- c) The machine must be used by appropriately trained people.
- d) The device must be assembled correctly before use.
- e) The device should be checked carefully before use. You should only work with an device that is in good condition. If you notice any defect on the machine that may cause danger to the operator, do not operate the device until defects are rectified.
- f) Replace worn or damaged parts for safety. Use only original spare parts. Parts not produced by manufacturer may cause poor fit and possible injury.
- g) Before use, all foreign bodies must be removed from the lawn, also pay attention to foreign bodies during the operation.
- h) Only work in daylight or sufficiently good artificial light.
- i) Wear eye protection and face or dust mask if operating in dusty conditions.
- j) Dress properly. Wear the following clothing while using the application:
 - Use of rubber gloves and substantial footwear is recommended.
 - Wear protective hair covering to contain long hair.
 - Avoid wearing loose clothing or jewelry that could get caught in the rotating tines.
 - Carry always resistant footwear and long trousers. Do not use the machine when they are bare feet or in sandals.

6) PROPER USE

The user is responsible for third parties while working with the device.

- a) People not acquainted with the operating instructions, children, juveniles who have not yet reached the minimum age for using this device, and people under the influence of alcohol, drugs or medication are not allowed to use the device.
- b) Children and adolescents under the age of 16 and persons unfamiliar with the instruction manual are not allowed to use the device.
- c) People whose physical, sensory or intellectual abilities are or who do not have the necessary experience and / or knowledge are not allowed to use the machine unless they are supervised or instructed about the handling of the machine by a person in charge of safety.
- d) Supervise children to make sure they do not play with the machine.
- e) Only use the device for its designed purposes.
- f) Keep children and pets away. All onlookers should be kept a safe distance away from the device when it is in use.
- g) Make sure that all the protective devices are fitted and in good condition.
- h) Do not operate the application near underground electric cables, telephone lines, pipes or hoses.
- i) Before connection the plug, make sure that the socket ratings are correct and correspond to those indicated on the rating label on the device.
- j) The use of the device is only permitted if the safety distance provided by the guide bar is complied with.
- k) Do not operate the application on a slope that is too steep for safe operation.
- l) When on slopes, slow down and make sure you have good footing.
- m) Before starting the application, make sure tines are not touching foreign objects and must be completely free to move.
- n) Grip guide bar firmly with both hands. Never operate the application with one hand.

- o) Be aware that the application may unexpectedly bounce upward or jump forward if the tines should strike extremely hard, packed soil, frozen ground, or buried obstacles such as large stones, roots or stumps.
- p) Do not put hands, feet or any body part or clothing in the vicinity of rotating tines. Caution! Risk of injury!
- q) Only guide the device at walking pace. Do not overreach. Always maintain proper footing and balance.
- r) Be aware of extension cord while operation. Be careful not to trip over cord. Always guide the cord away from tines.
- s) If the device strikes a foreign body, examine the application for signs of damage and carry out any necessary repairs before restarting and continuing to work.
- t) If the device should start to vibrate abnormally, switch off the motor and check for the cause immediately. Vibration is generally a warning of trouble.
- u) Holding the guide bar and lift the application to move it from one place to another.
- v) Always switch off the device, disconnect the plug and wait until the application stops before carrying out maintenance or cleaning work. Caution! Tines do not stop immediately after switching off.
- w) Use caution when cleaning or performing maintenance on the device. DANGER! Watch your fingers! Wear gloves!
- x) It is forbidden to move or modify any of the electrical and mechanical safety devices.
- y) The machine must be stopped when carrying out maintenance and cleaning operations, when changing tools or when transported by means other than under its own power. If the supply cord is damaged, it must be replaced by a special cord or assembly available from the manufacturer or its service agent.

7) ELECTRICAL SAFETY

- a) The mains voltage must correspond to the one marked on the technical data plate (230V~50Hz). Do not use other sources of power.
- b) The use of a safety circuit-breaker is recommended for the power supply line for an intervention range of 10 to 30 rated mA. Consult a reliable electrician.
- c) Never pass the device over the extension cable that the application is working, as this could cut the cable. Mark sure you always know where the cable is.
- d) Use the special cable holder for the connection of the extension cable.
- e) Never use the device when it is raining. Try to prevent it from getting wet or being exposed to humidity. Do not leave it outside overnight. Do not cut damp or wet grass.
- f) The power supply cable should be checked regularly and before using it each time, make sure the cable is not damaged or old out. If the cable is not in good condition, do not use the device; take it to an authorized service center instead.
- g) Only use an extension cable that is suitable for outdoor work. Keep it away from the cutting area, from damp, wet or oily surfaces or with sharp edges and away from heat and fuels.
- h) The mobile socket of the extension cable should be splash proof in compliance with DIN 57282 and VDE 0282 regulations; the cross-section of the wire (max. length 75 m) should be at least 1.5 mm^2 . Use H07RN-F harmonized cable.
- i) If the supply cord is damaged, it must be replaced by a special cord or assembly available from the manufacturer or its service agent.
- j) CAUTION: To avoid a hazard due to inadvertent resetting of the thermal cut-out, this appliance must not be supplied through an external switching device,







such as a timer, or connected to a circuit that is regularly switched on and off by the utility.

8) DOUBLE INSULATION

The application has double insulation. This means that all external metal parts are insulated from the electrical supply.

This is achieved by introducing an insulation layer between electrical and mechanical parts. The double insulation guarantees you the greatest possible safety.

9) EXPLANATION OF SYMBOLS

	Caution! The following warning symbols are to remind you of the safety precautions you should take when operating this tiller.
	Read the instruction manual and follow the warning and safety instructions!
	Caution! Always wear eye protection and earmuffs!
	Wear protective nonskid shoes
	Do not use this product in the rain or damp conditions. Protect it from moisture.
	Danger! Keep bystanders away from the danger zone!

	<p>Guarantee sound power level</p>
	<p>Danger! Keep hands and feet away from the cutting equipment!</p>
	<p>Always switch off the device, disconnect the power and wait till the machine comes to a standstill prior to maintenance, cleaning or repair work!</p>
	<p>Danger! Rotating blades. Keep hands and feet out of openings while machine is running.</p>
	<p>Caution! Unplug immediately if the power cord or plug becomes damaged!</p>
	<p>Double insulation.</p>
	<p>Waste electrical products should not be disposed of with household waste. Please recycle where facilities exist. Check with your local authority or retailer for recycling advice.</p>

3. YOUR PRODUCT

3.1 DESCRIPTION(FIG.1)

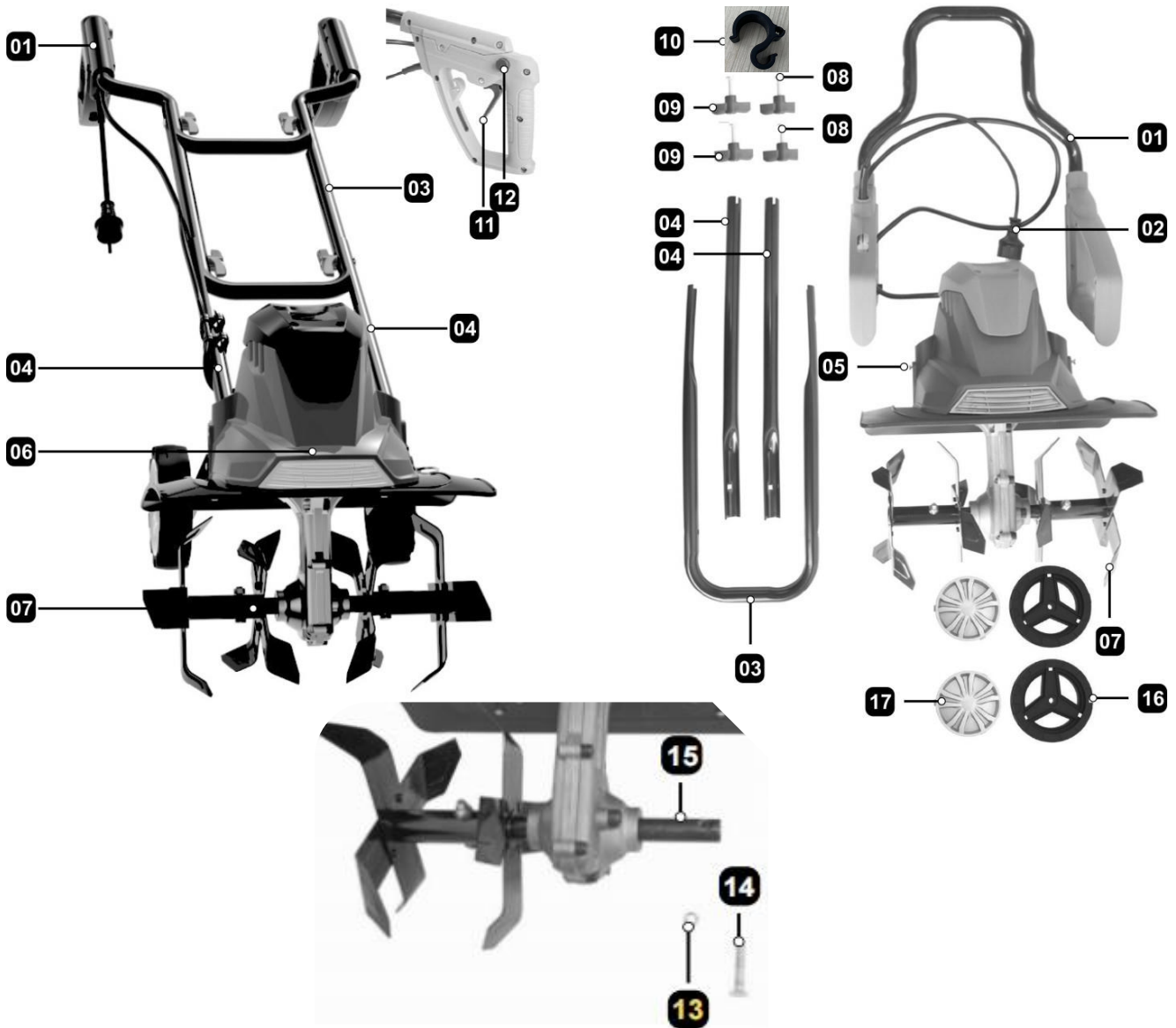

- 01. Handle
- 02. Power cord
- 03. Frame tubing
- 04. lower bar
- 05. Tapping screw
- 06. Machine frame

- 07. Blade roller
- 08. Carriage bolt
- 09. Wing nut
- 10. Cable clip
- 11. Safety release catch
- 12. On/Off switch

- 13. Nut M8
- 14. Screw M8
- 15. Drive shaft
- 16. wheel
- 17. wheel cover

3.2 TECHNICAL DATA

Model	RAC1200ET
Rated voltage	230-240V~
Rated frequency	50Hz
Input power	1200W
Working width	360mm
Wheels	Ø150mm
Weight	8.15kg
Measured Sound pressure level	81,3 dB(A) Uncertainty K=3.0 dB(A)
Measured Sound power level	91,64 dB(A) Uncertainty K=1,31dB(A)
Guaranteed sound power level	93 dB(A)
Vibration	Left handle: 0.764 m/s ² Right handle: 0.798m/s ² K=1.5 m/s ²

INFORMATION

- The declared vibration total value(s) and the declared noise emission value(s) have been measured in accordance with a standard test method and may be used for comparing one tool with another.
- The declared vibration total value(s) and the declared noise emission value(s) may also be used in a preliminary assessment of exposure.

WARNING!

- The vibration and noise emissions during actual use of the power tool can differ from the declared values depending on the ways in which the tool is used especially what kind of workpiece is processed.
- Need to identify safety measures to protect the operator that are based on an estimation of exposure in the actual conditions of use (taking account of all parts of the operating cycle such as the times when the tool is switched off and when it is running idle in addition to the trigger time).
- Wear hearing protection.

4. ASSEMBLY

! IMPORTANT! You must fully assemble the appliance before using it for the first time!

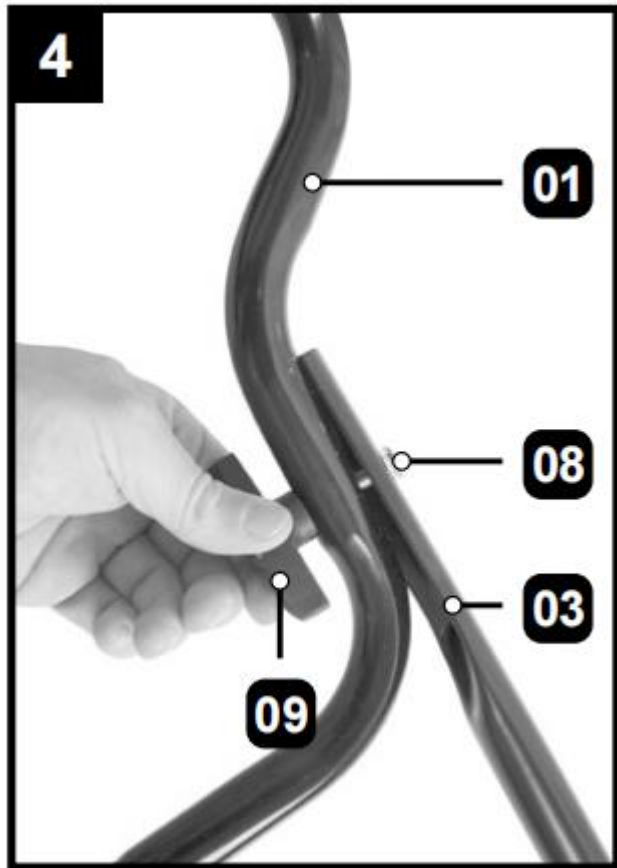
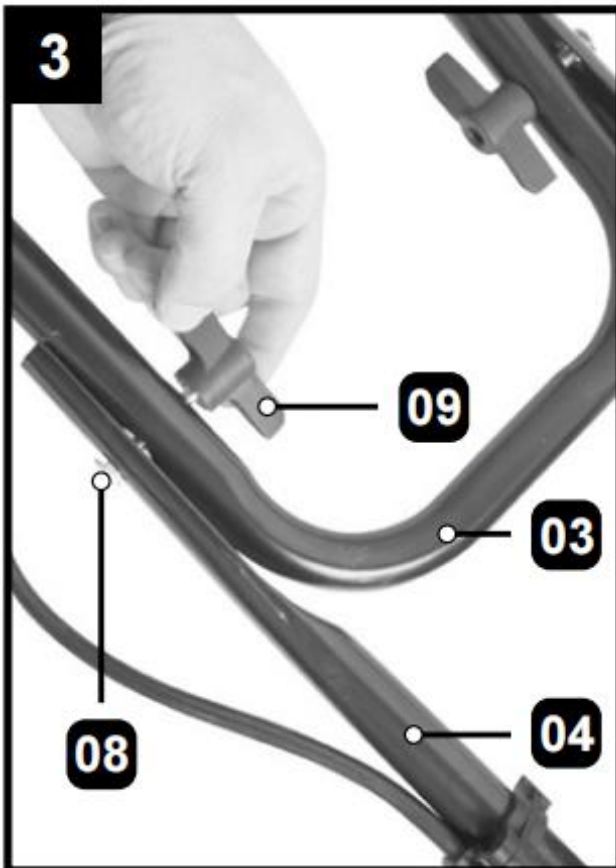
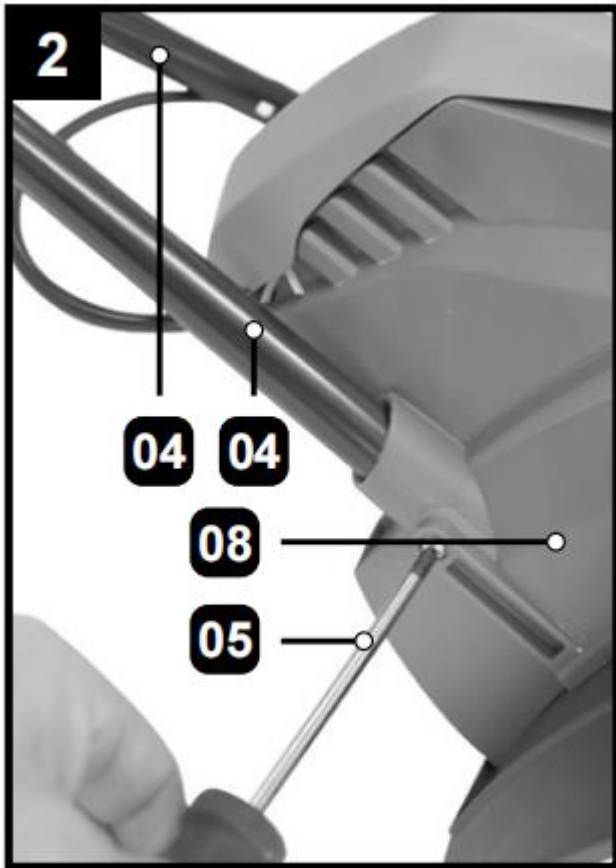

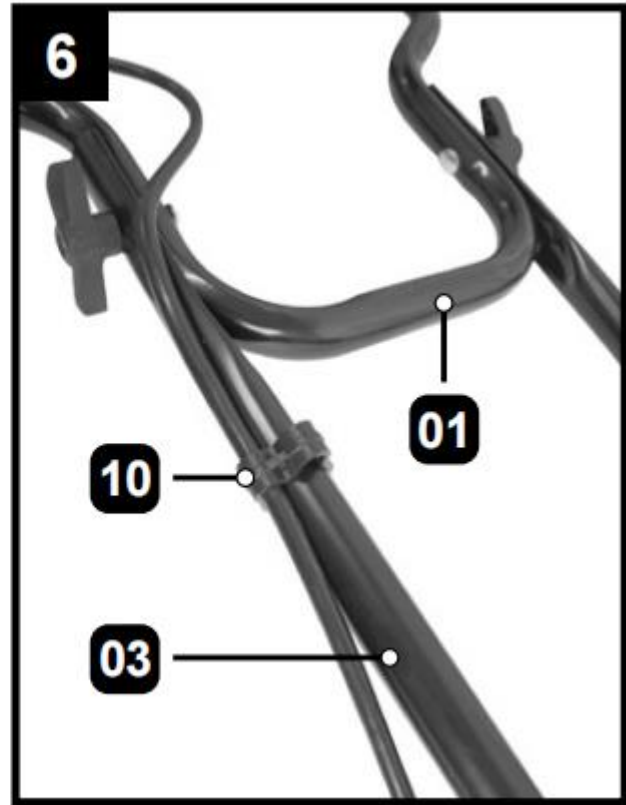
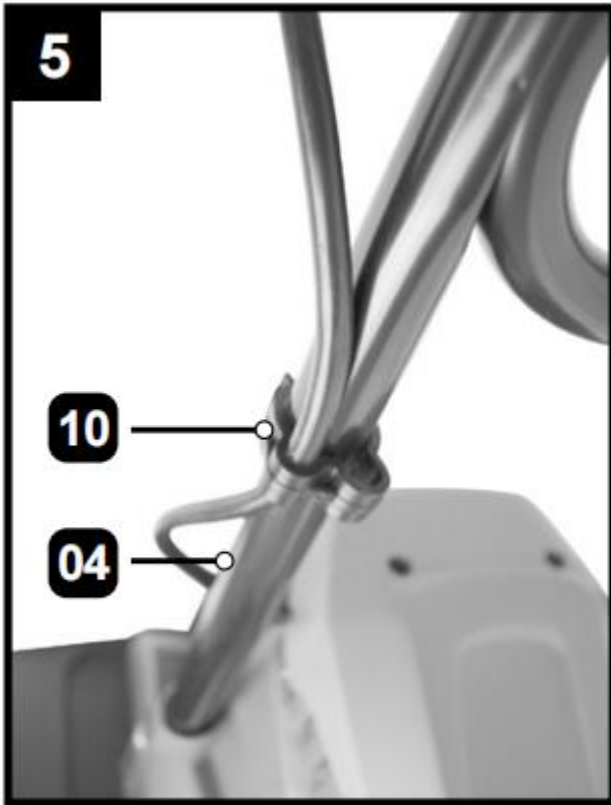

- Attach the lower bars (04) as shown in picture 2 and tighten the screws (05). (fig. 2)
- Connect the bar (03) and the handle (01) to the lower bars (04) using the wing nut (09) and lock screw (08) (fig. 3,4)
- Laying the power cord
 - Mount the cable and the cable guide (10) on the lower right bar (04) (fig. 5,6).
- Blade roller installing.

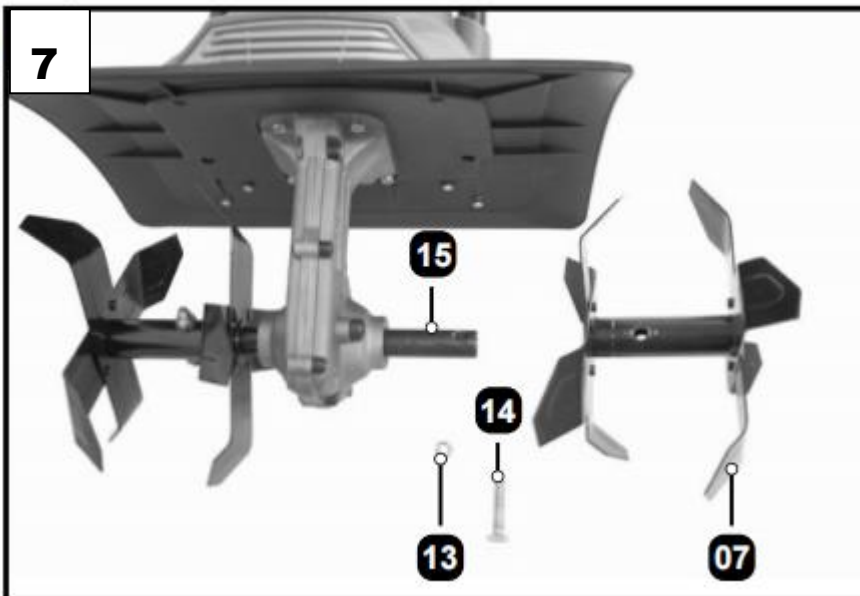

- Push the blade roller (07) on the drive shaft (15) of the machine. The blade roller (07) can be mounted on the left or right side. Be sure that the holes of the blade roller (07) and the drive shaft (15) are aligned. Now push through the Screw M8 (14) and fix it with the nut M8 (13). Lock the nut M8 (13) and tighten with hands. (fig. 7)
- For uninstall: Proceed in reverse order.

- Install the wheel

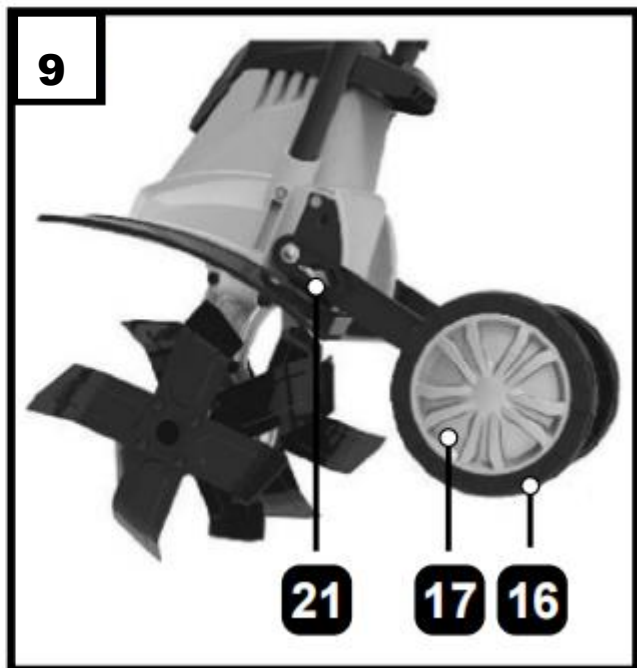
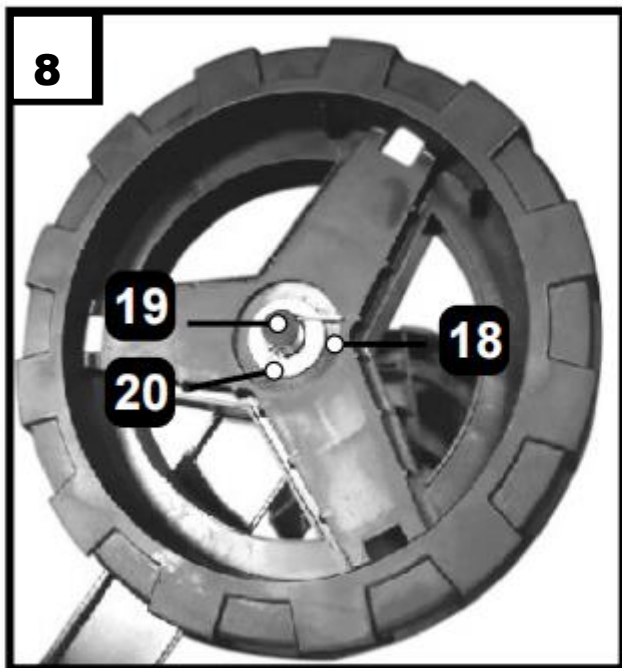

- Remove the pre-assembled split pin (20) and the washer (18). Place the wheel (16) on the wheel holder (19). Secure it with the washer (18) and the split pin (20). Then mount the wheel cap (17). (fig. 8,9)
- Assembly is identical on both sides.

Transport and storage

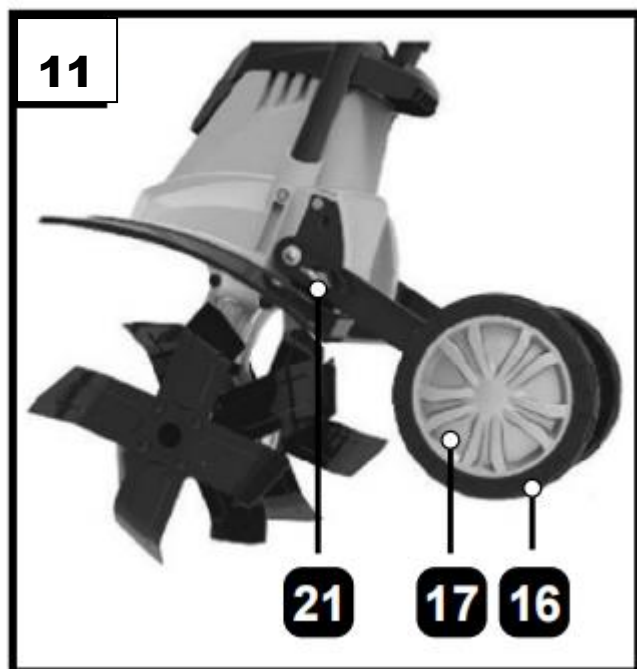
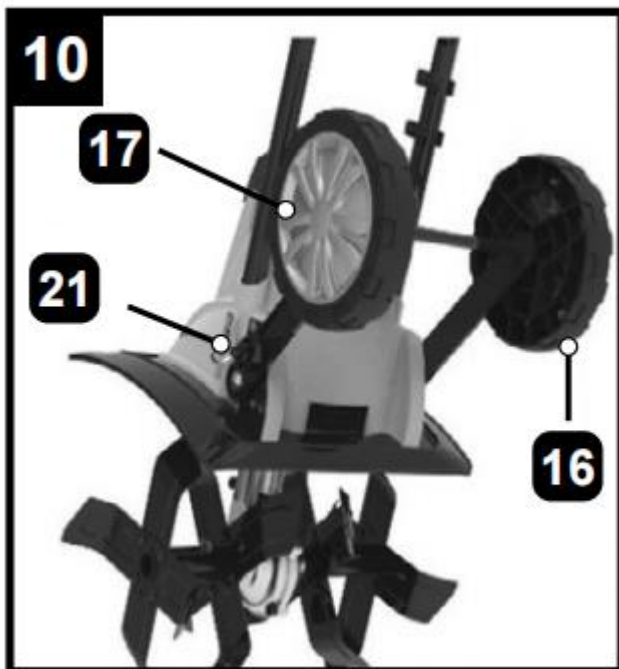

- Always pull out the power cord before transporting! Pull the lock pin (21). You can now move the wheels (16) to the lower position. Make sure that the lock pin (21) engages again in the lower position. (fig. 11)
- Attention! The wheels must be fixed in the upper position during operation! (fig. 10)
- For storage or transport in a limited space, proceed as follows: Open the wing nuts (09) until you can fold the handles forward. Attention! Danger of crushing your fingers.
- Now you can transport your machine with the transport handle (03).

So, you can storage the machine.

5. OPERATION

5.1 START AND STOP

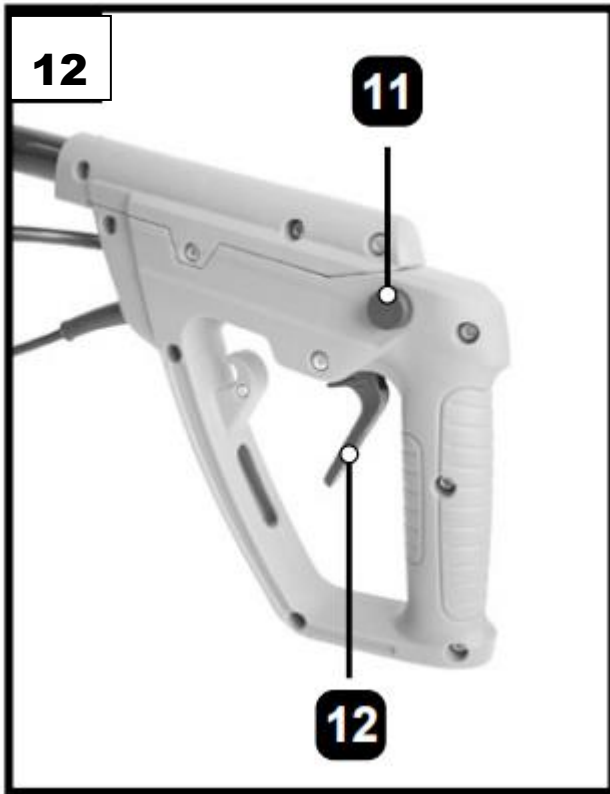

- To prevent an accidental start-up of the implement, the throttle handle (01) is equipped with a safety release switch (11) which must be pressed before the On/Off switch (12) can be pressed. If the On/Of switch (12) is released, the equipment switches off.

- Repeat this process several times so that you are sure that the machine functions properly. Before you perform any repair or maintenance work on the machine, ensure that the cutting unit is not rotating and that the power supply is disconnected.

- The safety distance between housing and user given by the handle (01) must always be observed. Be especially careful when digging and changing direction or slopes and inclines. Maintain a solid footing and wear sturdy, non-slip footwear and long trousers. Always dig along the incline (not up and down).

- For safety reasons, the Electric Tiller may not be

used to dig up inclines whose gradient exceeds

15 degrees. Use special caution when backing up and pulling the implement (tripping hazard)!

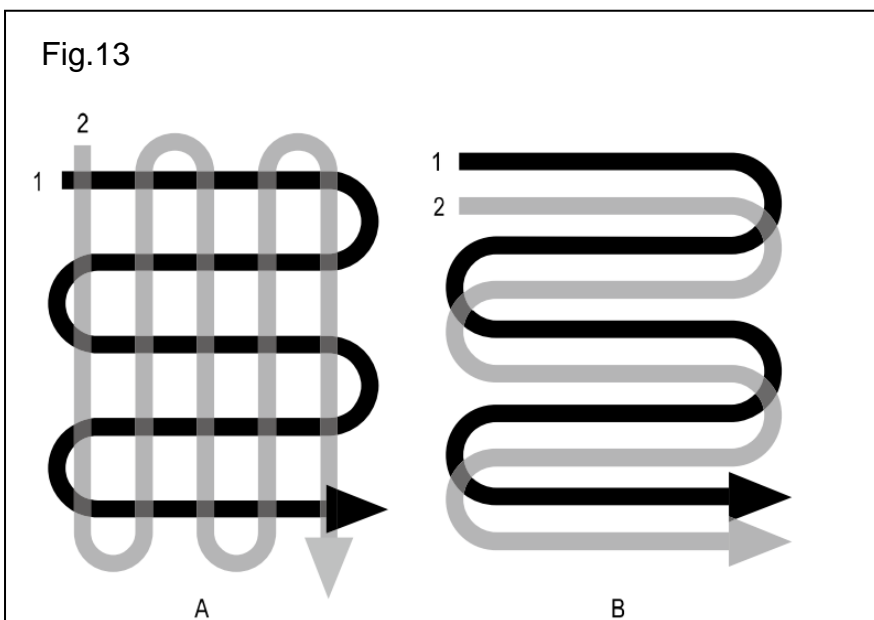

Tips

- Move the application to the work area prior to starting the motor.
- Hold the application firmly while switch on.
- The tines will pull the tiller forward during operation, press the guide bar to lower the tines slowly.
- By pulling tiller back towards yourself, the tines will dig deeper and more aggressively.

- For breaking sod or deep tilling, allow the tines to pull the tiller forward to the end of your arm's reach, then firmly pull the tiller back towards you. By repeatedly allowing the tiller to move forward and then pulling back to you, the tiller will be most effective.
- If the tiller digs deep enough to stay in one spot, gently rock the tiller side to side to start the tiller moving forward again.
- For preparing seed bed, we recommend using one of the tilling patterns shown in Fig. 14.
- Tilling Pattern A – Make two passes over area to be tilled, the second at a right angle to the first.
- Tilling Pattern B – Make two passes over area to be tilled, the second overlapping the first.
- To prevent tripping take particular care when moving backwards and when pulling the tiller.
- Always let the tines rotate at top speed; do not work in such a way as to overload the appliance.
- Never pass the tiller over the extension cord; make sure it is always in a safe position behind your back.
- When working on inclines always stand diagonally to the incline in a sturdy, safe stance. Do not work on extremely steep slopes.

6. MAINTENANCE AND STORAGE

The insulation on electrical connection cables is often damaged. This may have the following causes:

- Passage points, where connection cables are passed through windows or doors.
- Kinks where the connection cable has been improperly fastened or routed.
- Places where the connection cables have been cut due to being driven over.
- Insulation damage due to being ripped out of the wall outlet.
- Cracks due to the insulation ageing. Such damaged electrical connection cables must not be used and are life-threatening due to the insulation damage. Check the electrical connection cables for damage regularly. Make sure that the connection cable does not hang on the power network during the inspection.

Maintenance

- A worn out or damaged cutting unit should be replaced by an expert.
- Take care that all fastening elements (screws, nuts, etc.) are firmly tightened, so that you can work safely with the Electric Tiller.
- Store the Electric Tiller in a dry place.
- For longer life, all screw-fastened parts, such as wheels and axles should be cleaned and subsequently oiled.
- Regular servicing of the implement not only secures longer endurance and performance, it also contributes to an accurate and simple dig up of your bed.
- At the end of the season, carry out a general check of the Electric Tiller, and remove all residue collected. Before the start of every season, it is absolutely necessary to check the state of the machine. Contact our Customer Service if repair work is necessary.

CLEANING

- Keep all safety devices, air vents and the motor housing free of dirt and dust as far as possible. Wipe the equipment with a clean cloth or blow it with compressed air at low pressure.
- We recommend that you clean the device immediately each time you have finished using it.
- Clean the equipment regularly with a moist cloth and some soft soap. Do not use cleaning agents or solvents; these could attack the plastic parts of the equipment. Ensure that no water

can seep into the device. The ingress of water into an electric tool increases the risk of an electric shock.

STORAGE

Store the Tiller in a dry, clean area out of reach of children.

During extended periods of storage, ensure that the tiller/ cultivator is protected against corrosion and frost.

At the end of the season, or if the tiller is not being used for longer than a month, wipe over all metal surfaces with an oil impregnated cloth to protect them from corrosion or spray with a fine coat of oil. Fold the guide bar down, and store the tiller in a suitable place.

7. TROUBLESHOOTING

Problem	Possible causes	Remedy
Motor does not start	Unit not plugged in	Plug in the unit
	No electricity	Check power supply
	Defective cable	Check cable. Repair or replace if required
	Defective safety switch/plug	Arrange for repair
	Overheat protection activated	1. Working depth too large, set to a shorter depth. 2. Blades blocked, remove the blockage. 3. Soil too hard, select correct work depth and move forward and backward several times while slowing down the operation speed. Wait until the motor cools down for about 15 minutes before further use.
Abnormal noises	Blade is jammed	Switch off. Wait till tines come to a complete stop. Remove jammed objects.
	Lubrication running out	Tiller must be repaired. Call our customer service help line.
	Bolts, nuts or other components are loose.	Tighten all components. Arrange for repair if noises continue.
Abnormal vibrations	Blades damaged or worn	Replace damaged or worn blades.
	Working depth too large	Set to correct working depth.
Poor results	Working depth too small	Set to correct working depth.
	Worn blades	Replace damaged or worn blades.

8. DISPOSAL



Electrical products should not be discarded with household products. According to the European Directive 2012/19/UE on waste electrical and electronic equipment and its implementation into national law, electrical products used must be collected separately and disposed of at collection points provided for this purpose. Talk with your local authorities or dealer for advice on recycling.

9. DECLARATION OF CONFORMITY



BUILDER SAS
32, rue Aristide Bergès - ZI 31270 Cugnaux – France
declare that the machine
Electric tiller
Model: RAC1200ET

Serial number: 20221216351-20221216810
20230200231-20230200480

Is in conformity with the European Directives:

Machine Directive 2006/42/EC
EMC Directive 2014/30/EU
RoHs Directive (EU)2015/863 amending 2011/65/EU
Noise Directive 2000/14/EC amended by 2005/88/EC, Article 12, Annex III item 40.
This product is also in conformity with the following standards:

EN 60335-1:2012+A11+A13+A1+A14+A2

EN ISO 12100:2010

EN 709:1997+A4

EN 62233:2008

EN IEC 55014-1:2021

EN IEC 55014-2:2021

EN IEC 61000-3-2:2019+A1

EN 61000-3-3:2013+A1

EN ISO 3744: 1995, ISO 11094:1991
the noise notified body:

TÜV Rheinland LGA Products GmbH
under number 0197 at the EC Commission
Tillzstrasse 2 - 90431 Nürnberg

Measured Sound power level	91,64 dB(A) Uncertainty K=1,31dB(A)
Guaranteed sound power level	93 dB(A)

The technical documentation is kept by: Olivier Patriarca

Cugnaux, 19/09/2022

Philippe MARIE / PDG

10. WARRANTY

The manufacturer guarantees the product against defects in material and workmanship for a period of 2 years from the date of the original purchase. It can be extended by one year if the user subscribes to website of myswap. The warranty only applies if the product is for household use. The warranty does not cover breakdowns due to normal wear and tear.

The manufacturer agrees to replace parts identified as defective by the designated distributor. The manufacturer does not accept responsibility for the replacement of the machine, in whole or in part, and/or ensuing damage.

The warranty does not cover breakdowns due to:

insufficient maintenance.

abnormal assembly, adjustment or operations of the product.

parts subject to normal wear and tear.

The warranty does not extend to:

shipping and packaging costs.

using the tool for a purpose other than that for which it was designed.

the use and maintenance of the machine done in a manner not described in the user manual.

Due to our policy of continuous product improvement, we reserve the right to alter or change specifications without notice. Consequently, the product may be different from the information contained therein, but a modification will be undertaken without notice if it is recognized as an improvement of the preceding characteristic.

READ THE MANUAL CAREFULLY BEFORE USING THE MACHINE.

When ordering spare parts, please indicate the part number or code, you can find this in the spare parts list in this manual. Keep the purchase receipt; without it, the warranty is invalid. To help you with your product, we invite you to contact us by phone or via our website:

+33 (0)9.70.75.30.30

<https://services.swap-europe.com/contact>

You must create a "ticket" via the web platform.

Register or create your account.

Indicate the reference of the tool.

Choose the subject of your request.

Describe your problem.

Attach these files: invoice or sales receipt, photo of the identification plate (serial number), photo of the part you need (for example: pins on the transformer plug which are broken).



swap

11. PRODUCT FAILURE

WHAT TO DO IF MY MACHINE BREAKS DOWN?

If you bought your product in a store:

- Make sure that your machine is complete with all accessories supplied, and clean! If this is not the case, the repairer will refuse the machine.
- Go to the store with the complete machine and with the receipt or invoice.

If you bought your product on a website:

- Make sure that your machine is complete with all accessories supplied, and clean! If this is not the case, the repairer will refuse the machine.
- Create a SWAP-Europe service ticket on the site: <https://services.swap-europe.com> When making the request on SWAP-Europe, you must attach the invoice and the photo of the nameplate (serial number).

Contact the repair station to make sure it is available before dropping off the machine.

Go to the repair station with the complete machine packed, accompanied by the purchase invoice and the station support sheet downloadable after the service request is completed on the SWAP-Europe site

Please keep your original packaging to allow for after-sales service returns or pack your machine with a similar cardboard box of the same dimensions.

For any question concerning our after-sales service you can make a request on our website <https://services.swap-europe.com>

Our hotline remains available at +33 (9) 70 75 30 30.



12. WARRANTY EXCLUSIONS

THE WARRANTY DOES NOT COVER:

- Start-up and setting up of the product.
- Damage resulting from normal wear and tear of the product.
- Damage resulting from improper use of the product.
- Damage resulting from assembly or start-up not in accordance with the user manual.
- Breakdowns related to carburetion beyond 90 days and fouling of carburetors.
- Periodic and standard maintenance events.
- Actions of modification and dismantling that directly void the warranty.
- Products whose original authentication marking (brand, serial number) has been degraded, altered or withdrawn.
- Replacement of consumables.
- The use of non-original parts.
- Breakage of parts following impacts or projections.
- Accessories breakdowns.
- Defects and their consequences linked to any external cause.
- Loss of components and loss due to insufficient screwing.
- Cutting components and any damage related to the loosening of parts.
- Overload or overheating.
- Poor power supply quality: faulty voltage, voltage error, etc.
- Damages resulting from the deprivation of enjoyment of the product during the time necessary for repairs and more generally the costs related to the immobilization of the product.
- The costs of a second opinion established by a third party following an estimate by a SWAP-Europe repair station
- The use of a product which would show a defect or a breakage which was not the subject of an immediate report and/or repair with the services of SWAP-Europe.
- Deterioration linked to transport and storage*.
- Launchers beyond 90 days.
- Oil, petrol, grease.
- Damages related to the use of non-compliant fuels or lubricants.

* In accordance with transport legislation, damage related to transport must be declared to carriers within 48 hours maximum after observation by registered letter with acknowledgement of receipt. This document is a supplement to your notice, a non-exhaustive list.

Attention: all orders must be checked in the presence of the delivery person. In case of refusal by the delivery person, it you must simply refuse the delivery and notify your refusal.

Reminder: the reserves do not exclude the notification by registered letter with acknowledgement within 72 hours.

Information:

Thermal devices must be wintered each season (service available on the SWAP-Europe site). Batteries must be charged before being stored.



BUILDER SAS

32, rue Aristide Bergès - ZI 31270 Cugnaux - France

MADE IN PRC 2022